

SET-UP SHEET



NAME	Nic Michaelides	
CITY/COUNTRY	Melbourne	Australia
CONTACT	na	

RACE	Geelong Club Day - November	
TRACK	Geelong	

Motor Turn: 21.5 Blinky

TRACK CONDITION	<input type="checkbox"/> TECHNICAL	<input checked="" type="checkbox"/> CARPET	<input type="checkbox"/> ASPHALT
	<input type="checkbox"/> MIXED	<input type="checkbox"/> FAST	
TRACTION	<input type="checkbox"/> LOW	<input type="checkbox"/> MEDIUM	<input checked="" type="checkbox"/> HIGH

DATE	7/11/21	TEMPERATURE/ FOR °C	16	ATR		TRACK	
------	---------	---------------------	----	-----	--	-------	--

PINION-T	40	SPUR GEAR/T	98
----------	----	-------------	----

	FRONT	REAR
OIL/CST	450cst	450cst
LENGTH		
REBOUND%	0	0

SUSPENSION SPRING		FRONT	REAR
129345	1.4*19*4.5 RD		
129350	1.4*19*5.0 SR		
129355	1.4*19*5.5 YE	Gold	Gold
129360	1.4*19*6.0 BL		

<input type="checkbox"/> YES <input checked="" type="checkbox"/> NO	FOAM INSERTS	<input type="checkbox"/> YES <input checked="" type="checkbox"/> NO
<input type="checkbox"/> YES <input checked="" type="checkbox"/> NO	O-RING ON SHAFT	<input type="checkbox"/> YES <input checked="" type="checkbox"/> NO

		PISTONS	
<input type="checkbox"/> ○	0 HOLES	2.0mm	<input type="checkbox"/> ○
<input type="checkbox"/> ○	1 HOLES	2.0mm	<input type="checkbox"/> ○
<input type="checkbox"/> ○	2 HOLES	2.0mm	<input type="checkbox"/> ○
<input checked="" type="checkbox"/> ○	3 HOLES	2.0mm	<input checked="" type="checkbox"/> ○

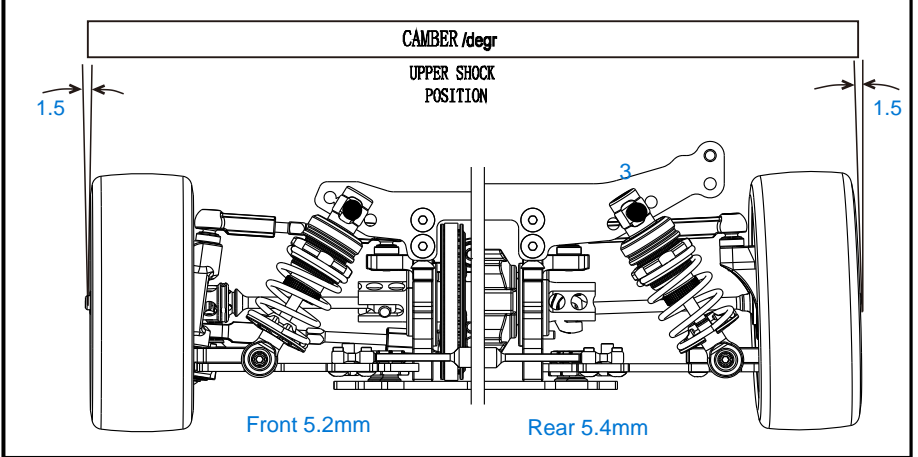
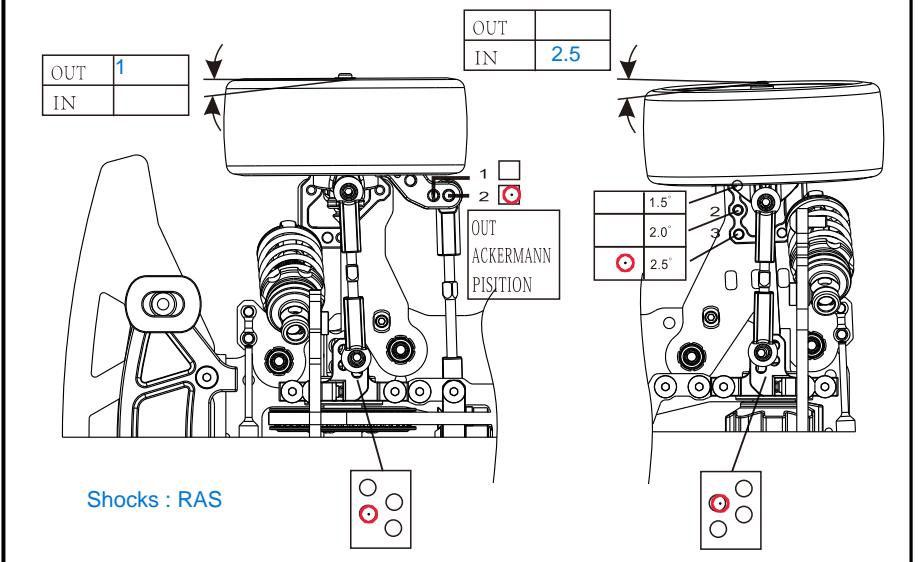
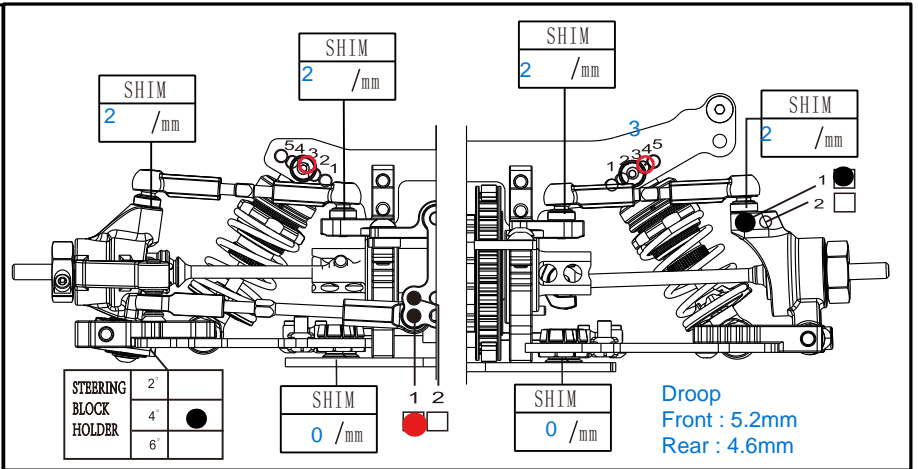

FRONT	THICKNESS/mm	ANTI ROLL BAR	THICKNESS/mm	BACK	Tire Set used: Team Powers 36SU
	1.2mm	<input type="checkbox"/>		1.2mm	
	1.4mm	<input checked="" type="checkbox"/>		1.4mm	
	1.6mm	<input checked="" type="checkbox"/>		1.6mm	
	1.8mm	<input type="checkbox"/>		1.8mm	
	2.0mm	<input type="checkbox"/>		2.0mm	



SET-UP SHEET

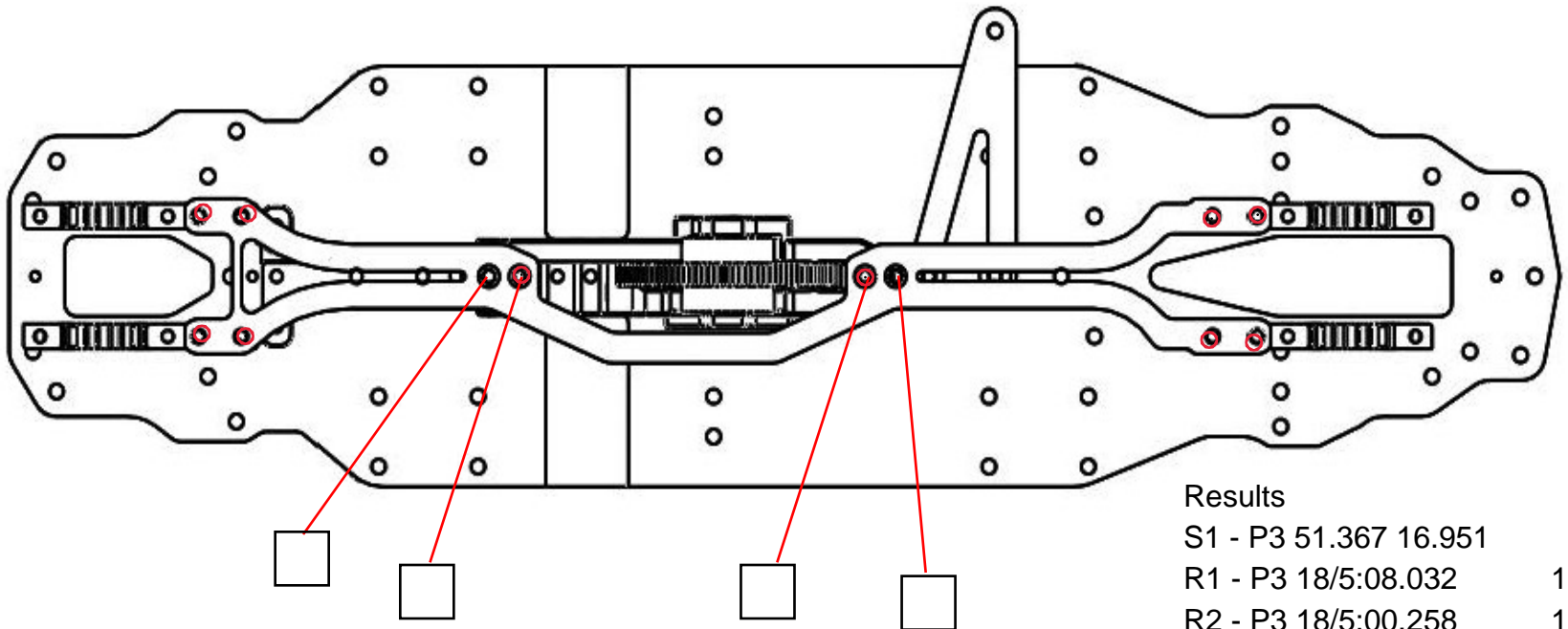

Gear Diff Oil: 3000cst

Results

S1 - P3	51.367	16.951
R1 - P3	18/5:08.032	16.708
R2 - P3	18/5:00.258	16.491
R3	DNS	
R4 - P3	18/5:00.474	16.497

Comments

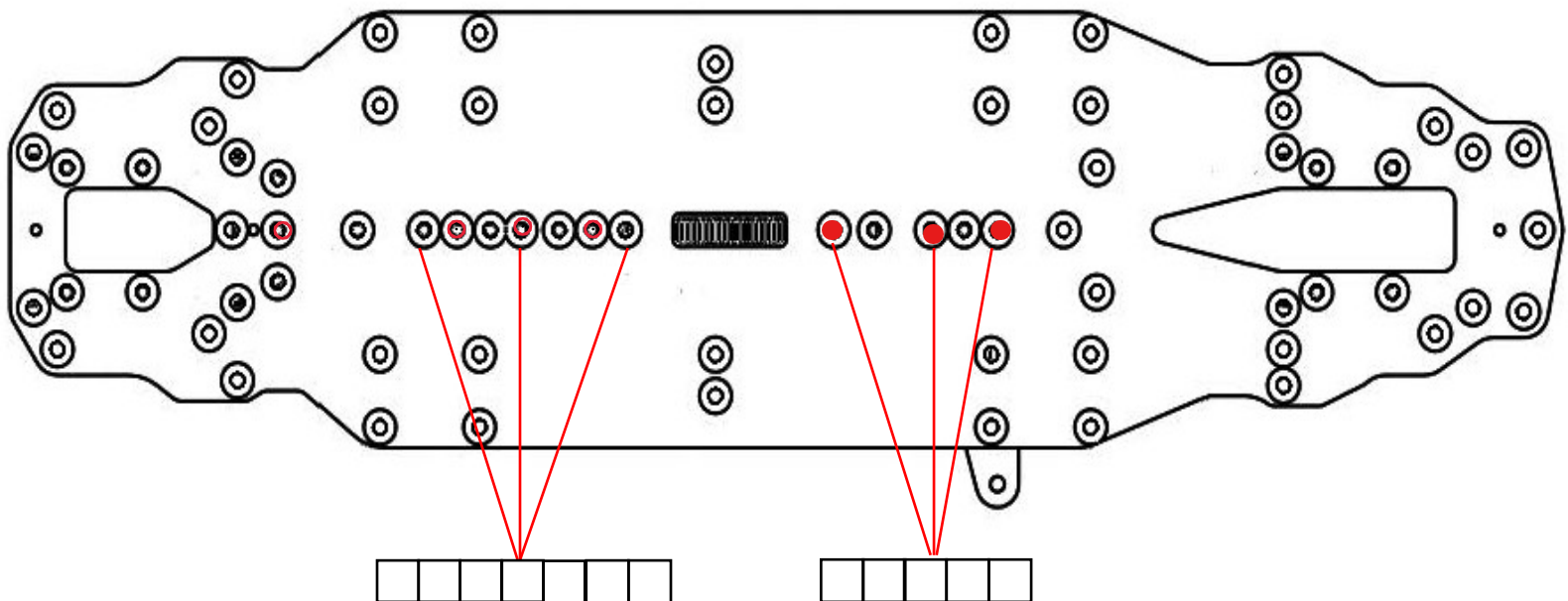

Car Weight - 1323g / Shell - Zoo Wolverine